

Automatic Screw Feeder

自動供給螺絲鎖緊機 AUTOMATIC SCREW FEEDER



CM-T6

- 依照快速、穩定、方便之設計原則，結合氣(電)動螺絲起子、高科技自動送料機及高精度螺絲夾具，以提昇螺絲鎖付速度、大幅增進生產效率。
- 螺絲夾具依客戶螺絲、工作環境量身設計，以確保作業順暢穩定。
- 以氣動起子為標準規格，亦可搭配客戶指定型號。
- Designed for speed, stability, and convenience.
- Improving screw driving speed and work efficiency by integrating pneumatic/ electrical screwdriver, high-tech automatic feeder, and high precision jaw.
- The jaw is customized by particular screw and working environment to provide a stable operation.
- Standard pneumatic screwdriver; optional models by customer also available.



CM-20

CM-30

規格 Specification

| 型號 Model | 長/寬/高 L / W / H | 重量 Weight | 電壓 Voltage | 最大氣壓 Air Pressure |
|-------------|--------------------|--------------|---------------|------------------------|
| CM-20 | 28 / 17 / 17 (cm) | 10 kg | 220 V | 5 kg / cm ² |
| CM-30 | 35 / 25 / 38 (cm) | 22 kg | 220 V | 5 kg / cm ² |

| 型號 Model | 螺絲規格 Screw Size | 螺絲長度 Screw Length(A) | 最大頭徑 Max Screw Head | 頭徑公差 Tolerance | 丸頭 Pan Head | 平頭 Flat Head | 六角孔 Hex Socket |
|-------------|--------------------|-------------------------|------------------------|-------------------|-------------------------------------|-------------------------------------|-------------------------------------|
| CM-20 | M 1.6 | 4-12 | (A) 1.5 | ± 0.1 | <input checked="" type="checkbox"/> | <input checked="" type="checkbox"/> | <input checked="" type="checkbox"/> |
| | M 2.0 | 5-20 | | | <input checked="" type="checkbox"/> | <input checked="" type="checkbox"/> | <input checked="" type="checkbox"/> |
| | M 2.5 | 6-20 | | | <input checked="" type="checkbox"/> | <input checked="" type="checkbox"/> | <input checked="" type="checkbox"/> |
| CM-30 | M 3 | 6-22 | (A) 1.3 ~10.5 | ± 0.2 | <input checked="" type="checkbox"/> | <input checked="" type="checkbox"/> | <input checked="" type="checkbox"/> |
| | M 4 | 8-25 | | | <input checked="" type="checkbox"/> | <input checked="" type="checkbox"/> | <input checked="" type="checkbox"/> |
| | M 5 | 10-25 | | | <input checked="" type="checkbox"/> | <input checked="" type="checkbox"/> | <input checked="" type="checkbox"/> |
| | M 6 | 12-25 | | | <input checked="" type="checkbox"/> | <input checked="" type="checkbox"/> | <input checked="" type="checkbox"/> |

實用圖 Demonstration



結構圖 Dimension

CM-20

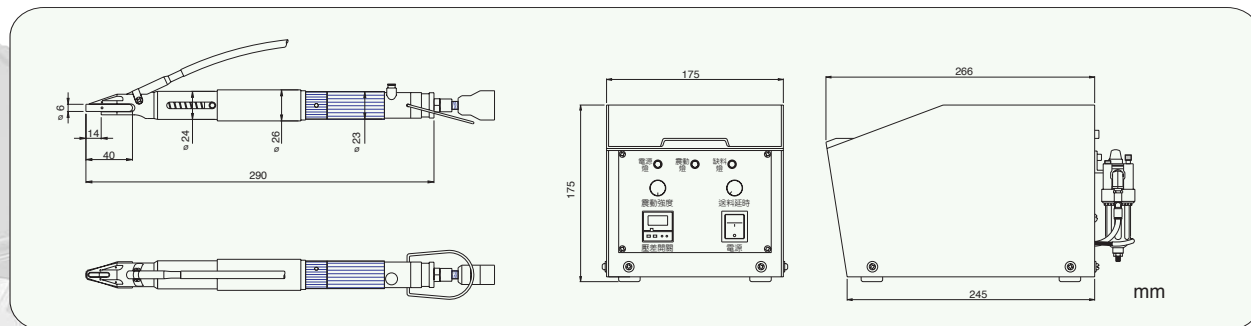

CM-30

